

OSP1250-3140xxR

1.25Gb/s SFP EX Optical Transceiver Module, Single Mode, 1310nm, 40km Reach

Features

- Support up to 1.25Gb/s data links
- Compliant with SFP MSA standard
- Compliant with IEEE 802.3z
- Hot pluggable SFP footprint
- 1310nm DFB laser transmitter and PIN photo-detector
- Single 3.3V power supply
- Duplex LC connector
- Low power dissipation
- Metal enclosure provides lower EMI
- ROHS compliant and Lead Free
- Operating Temperature: Standard 0~70°C Extended -10~85°C Industrial -40~85°C
- Optional Digital Diagnostic Monitor Interface



Applications

- 1G Fiber Channel, Switch to Switch Interface
- Gigabit Ethernet, Switched Backplane Applications
- Broadband aggregation and wireless infrastructure
- Router/Server Interface
- Other Optical networking

Description

Optcore OSP1250-3140xxR is high performance and cost-effective small form factor pluggable (SFP) transceiver module for 1000BASE-EX/1000BASE-LH Gigabit Ethernet per IEEE802.3z and 1G Fiber Channel application. It supports dual data-rate of 1.25Gbps/1.06Gbps and 40km transmission distance with 9/125um single mode fiber. This 1.25G SFP EX transceiver module fully complies with the SFP Multi-Sourcing Agreement (MSA) and can be used on MSA compliant SFP ports of optical networking equipment. The transmitter section uses a 1310nm DFB laser that is a class 1 laser product compliant according to International Safety Standard IEC 60825. The receiver section uses a high-speed PIN photo-diode integrated with a trans-impedance preamplifier (TIA).

There are three versions of the series 1.25Gb/s SFP EX optical transceiver modules for different applications. The Standard grade (0~70°C) is for commonly commercial application, the Extended grade (-10~85°C) is for Extended temperature application, and the Industrial grade (-40~85°C) is made with robust and reliable components to meet the needs of Industrial Ethernet application under harsh environmental conditions.

Related Products

- OSP1250-8505XXR: 1.25Gb/s SFP SX Transceiver Module, Multit-mode, 850nm, 550m, LC
- OSP1250-3120XXR: 1.25Gb/s SFP LX Transceiver Module, Single mode, 1310nm, 20km, LC
- OSP1250-5580XXR: 1.25Gb/s SFP ZX Transceiver Module, Single mode, 1550nm, 80km, LC
- OSP1250-55A2XXR: 1.25Gb/s SFP EZX Transceiver Module, Single mode, 1550nm, 120km, LC

- OSP1250-55A6XXR: 1.25Gb/s SFP EZX+ Transceiver Module, Single mode, 1550nm, 150~160km, LC

Absolute Maximum Ratings

Parameter	Symbol	Min	Max	Unit	Notes
Maximum Supply Voltage	V _{cc}	-0.5	4.0	V	
Storage Temperature	T _s	-40	85	°C	
Operating Humidity	RH	5	95	%	

Recommended Operating Conditions

Parameter	Symbol	Min.	Typ.	Max.	Unit	Notes
Power Supply Voltage	V _{cc}	3.13	3.3	3.47	V	
Power Supply Current	I _{cc}			250	mA	
Case Operating Temperature	T _c	0		70	°C	Standard
		-10		85	°C	Extended
		-40		85	°C	Industrial
Data Rate			1.25		Gbps	Gigabit Ethernet
			1.06		Gbps	Fiber Channel
Transmission Distance				40	km	9/125μm SMF

Optical Characteristics

Parameter	Symbol	Min.	Typ.	Max.	Unit	Notes
Transmitter						
Center Wavelength	λ _c	1270	1310	1360	nm	
Average Output Power	P _{Out}	-5		0	dBm	1
Spectral Width (RMS)	σ			1	nm	
Extinction Ratio	ER	9			dB	1
Optical Rise/Fall Time	Tr-Tf			0.26	ns	2
Total Jitter				0.431	UI	
Output Optical Eye	Compliant with IEEE802.3 z (class 1 laser safety)					
Receiver						
Center Wavelength	λ _c	1270	-	1610	nm	
Receiver Sensitivity				-24	dBm	3
Receiver Overload		0			dBm	3
LOS De-Assert	LOSD			-25	dBm	
LOS Assert	LOSA	-35			dBm	
LOS Hysteresis		0.5		6	dB	

Note :

1. Measured at 1.25Gbps with PRBS 2⁷- 1 NRZ test pattern.
2. Unfiltered, measured with a PRBS 2⁷-1 test pattern @1.25Gbps
3. Measured at 1250 Mb/s with PRBS 2⁷- 1 NRZ test pattern for BER < 1x10⁻¹²

Electrical Input/Output Characteristics

Parameter	Symbol	Min.	Typ.	Max.	Unit	Notes
Transmitter						
Input differential impedance	Z _{IN}		100		Ω	
Data Input Swing Differential	V _{in,pp}	300		1600	mV	
TX Disable - High	V _{IH}	2.0		V _{cc} +0.3	V	
TX Disable - Low	V _{IL}	0		0.8	V	
TX Fault - High	V _{OH}	2.0		V _{cc} +0.3	V	
TX Fault - Low	V _{OL}	0		0.5	V	
Receiver						
Data Output Swing Differential	V _{out,pp}	400		1000	mV	
RX LOS - High	V _{Los}	2.0		V _{cc} +0.3	V	
RX LOS - Low	V _{Los}	0		0.8	V	

Pin Definitions

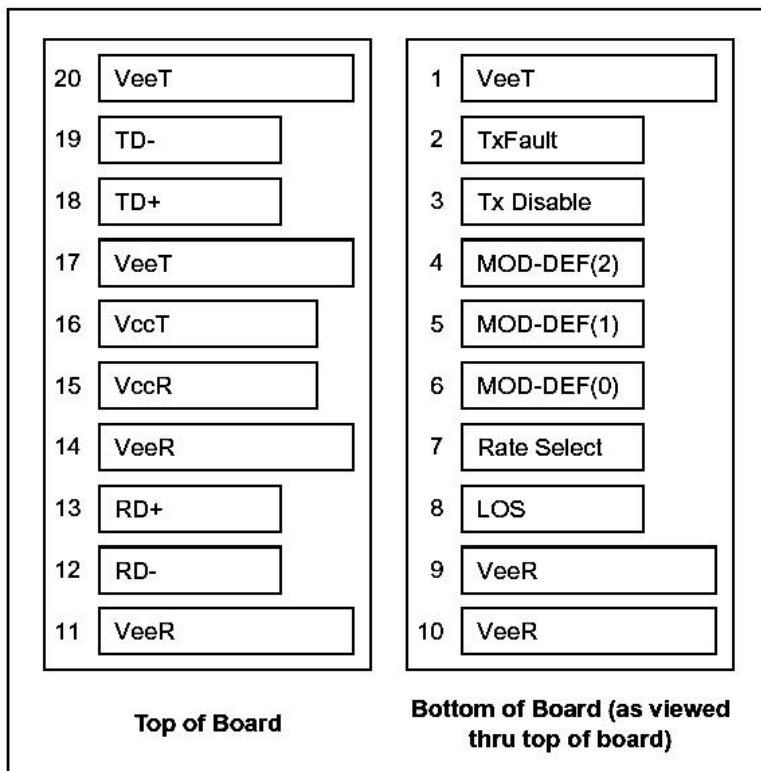

Pin Descriptions

Pin	Signal Name	Description	Plug Seq.	Notes
1	V _{EET}	Transmitter Ground	1	

2	TX FAULT	Transmitter Fault Indication	3	Note 1
3	TX DISABLE	Transmitter Disable	3	Note 2
4	MOD_DEF(2)	SDA Serial Data Signal	3	Note 3
5	MOD_DEF(1)	SCL Serial Clock Signal	3	Note 3
6	MOD_DEF(0)	Model present indication	3	Note 3
7	Rate Select	Not Connected	3	
8	LOS	Loss of Signal	3	Note 4
9	V _{EER}	Receiver ground	1	
10	V _{EER}	Receiver ground	1	
11	V _{EER}	Receiver ground	1	
12	RD-	Inverse Received Data Out	3	Note 5
13	RD+	Received Data Out	3	Note 5
14	V _{EER}	Receiver ground	1	
15	V _{CCR}	Receiver Power Supply	2	
16	V _{CCT}	Transmitter Power Supply	2	
17	V _{EET}	Transmitter Ground	1	
18	TD+	Transmit Data In	3	Note 6
19	TD-	Inv. Transmit Data In	3	Note 6
20	V _{EET}	Transmitter Ground	1	

Notes:

- TX Fault is an open collector output, which should be pulled up with a 4.7k~10kΩ resistor on the host board to a voltage between 2.0V and V_{CC}+0.3V. Logic 0 indicates normal operation; Logic 1 indicates a laser fault of some kind. In the low state, the output will be pulled to less than 0.8V.
- TX Disable is an input that is used to shut down the transmitter optical output. It is pulled up within the module with a 4.7k~10kΩ resistor. Its states are:
 Low (0 to 0.8V): Transmitter on (>0.8V, < 2.0V): Undefined
 High (2.0 to 3.465V): Transmitter Disabled Open: Transmitter Disabled
- Mod-Def 0,1,2. These are the module definition pins. They should be pulled up with a 4.7k~10kΩ resistor on the host board. The pull-up voltage shall be V_{CC}T or V_{CC}R.
 Mod-Def 0 is grounded by the module to indicate that the module is present
 Mod-Def 1 is the clock line of two wire serial interface for serial ID
 Mod-Def 2 is the data line of two wire serial interface for serial ID
- LOS is an open collector output, which should be pulled up with a 4.7k~10kΩ resistor. Pull up voltage between 2.0V and V_{CC}+0.3V. Logic 1 indicates loss of signal; Logic 0 indicates normal operation. In the low state, the output will be pulled to less than 0.8V.
- RD-/+ : These are the differential receiver outputs. They are internally AC-coupled 100 differential lines which should be terminated with 100Ω (differential) at the user SERDES.
- TD-/+ : These are the differential transmitter inputs. They are internally AC-coupled, differential lines with 100Ω differential termination inside the module.

Digital Diagnostic Functions

Optcore 1.25Gb/s SFP EX optical transceiver support the 2-wire serial communication protocol as defined in the SFP MSA. It is very closely related to the E2PROM defined in the GBIC standard, with the same electrical specifications. The standard SFP serial ID provides access to identification information that describes the transceiver’s capabilities, standard interfaces, manufacturer, and other information.

Additionally, Optcore 1.25Gb/s SFP EX optical transceiver provide an optional enhanced digital diagnostic monitoring interface, which allows real-time access to device operating parameters such as **transceiver temperature, laser bias current, transmitted optical power, received optical power and transceiver supply voltage**. It also defines a sophisticated system of alarm and warning flags, which alerts end-users when particular operating parameters are outside of a factory set normal range.

The SFP MSA defines a 256-byte memory map in E2PROM that is accessible over a 2-wire serial interface at the 8 bit address 1010000X (A0h). The digital diagnostic monitoring interface makes use of the 8 bit address 1010001X (A2h), so the originally defined serial ID memory map remains unchanged. The interface is identical to, and is thus fully backward compatible with both the GBIC Specification and the SFP Multi Source Agreement.

The operating and diagnostics information is monitored and reported by a Digital Diagnostics Transceiver Controller (DDTC) inside the transceiver, which is accessed through a 2-wire serial interface. When the serial protocol is activated, the serial clock signal (SCL, Mod Def 1) is generated by the host. The positive edge clocks data into the SFP transceiver into those segments of the E2PROM that are not write-protected. The negative edge clocks data from the SFP transceiver module. The serial data signal (SDA, Mod Def 2) is bi-directional for serial data transfer. The host uses SDA in conjunction with SCL to mark the start and end of serial protocol activation. The memories are organized as a series of 8-bit data words that can be addressed individually or sequentially.

Digital diagnostics for this 1.25G SFP EX optical transceiver is internally calibrated by default.

Mechanical Dimensions

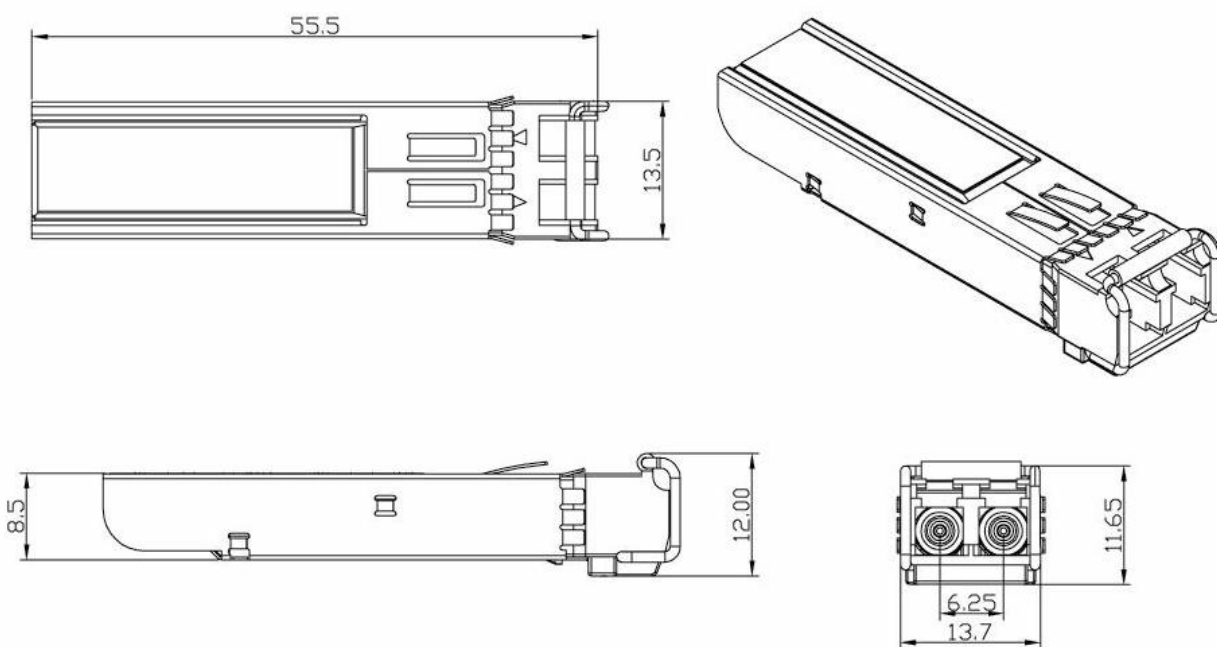

Ordering information

Part number	Description
OSP1250-3140NCR	1.25Gb/s SFP Transceiver,Single mode, 1310nm, 40km, LC, 0°C~+70°C
OSP1250-3140DCR	1.25Gb/s SFP Transceiver, Single mode, 1310nm, 40km, LC, DDM, 0°C~+70°C
OSP1250-3140NER	1.25Gb/s SFP Extended Transceiver, Single mode, 1310nm, 40km, LC, -10°C~+85°C
OSP1250-3140DER	1.25Gb/s SFP Extended Transceiver,Single mode,1310nm, 40km, LC, DDM, -10°C~+85°C
OSP1250-3140NTR	1.25Gb/s SFP Industrial Transceiver, Single mode, 1310nm, 40km, LC, -40°C~+85°C
OSP1250-3140DTR	1.25Gb/s SFP Industrial Transceiver, Single mode, 1310nm, 40km, LC, DDM, -40°C~+85°C

Warnings

Process plug

The transceiver optics is supplied with a dust cover. This plug protects the transceiver optics during standard manufacturing processes by preventing contamination from air borne particles.It is recommended that the dust cover remain in the transceiver whenever an optical fiber connector is not inserted.

Handling Precautions

The transceiver optics is susceptible to damage as a result of electrostatic discharge (ESD). A static free environment is highly recommended. Follow guidelines according to proper ESD procedures.

Laser Safety

The transceiver optics is a Class 1 laser product per international standard IEC 60825-1. Radiation emitted by laser devices can be dangerous to human eyes. Avoid eye exposure to direct or indirect radiation.

For more product information, visit us on the web at www.optcore.net



DS/VER170510/EN Copyright © 2017 Optcore Technology Co.,Ltd. All rights reserved. Optcore, Optcore logo are registered trademarks of Optcore Technology Co.,Ltd. All other brands, product names, or trademarks mentioned are the property of their respective owners. Specifications and product availability are subject to change without notice. Optcore assumes no responsibility for inaccuracies contained herein.

